

MOTOR DIMENSIONS

NEMA PREMIUM EFFICIENT JP FRAME 3 PHASE 1750 RPM

HP	Type	Frame	D	E	F	O	AB	BG	L	MH
30	ODP	JP286	7.00	5.50	4.75	13.63	12.21	10.25	11.19	0.53
40	ODP	JP324	8.00	6.25	5.25	14.63	12.21	10.51	11.43	0.66
50	ODP	JP326	8.00	6.25	6.00	14.63	12.21	11.29	10.68	0.66
30	TEFC	JP286	7.00	5.50	5.50	14.11	11.07	10.02	13.04	0.53
40	TEFC	JP324	8.00	6.25	5.25	15.93	12.58	10.25	13.83	0.66
50	TEFC	JP326	8.00	6.25	6.00	15.93	12.58	11.00	14.60	0.66

D097JP324

DRAWING DEPICTS JP324 40HP ODP MOTOR

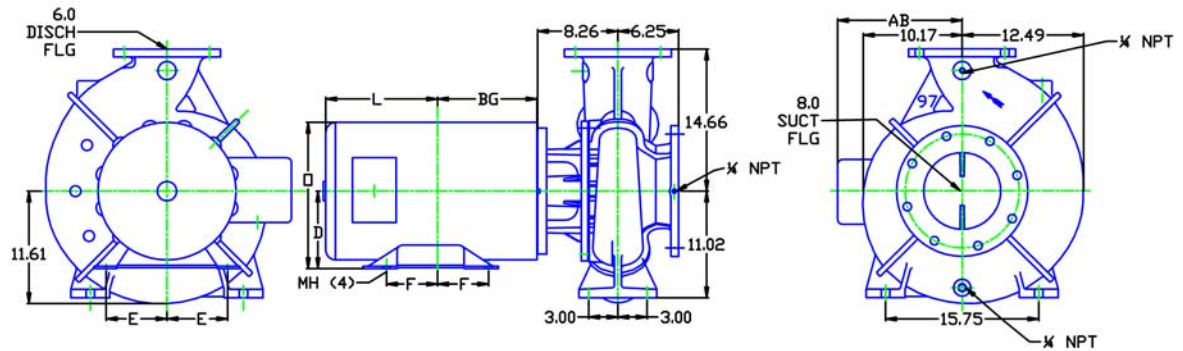

ALL DIMENSIONS IN INCHES.

DRAWING REPRESENTS APPROXIMATE PUMP DIMENSIONS. AUTOCAD DRAWING TO SCALE AVAILABLE FROM FACTORY.

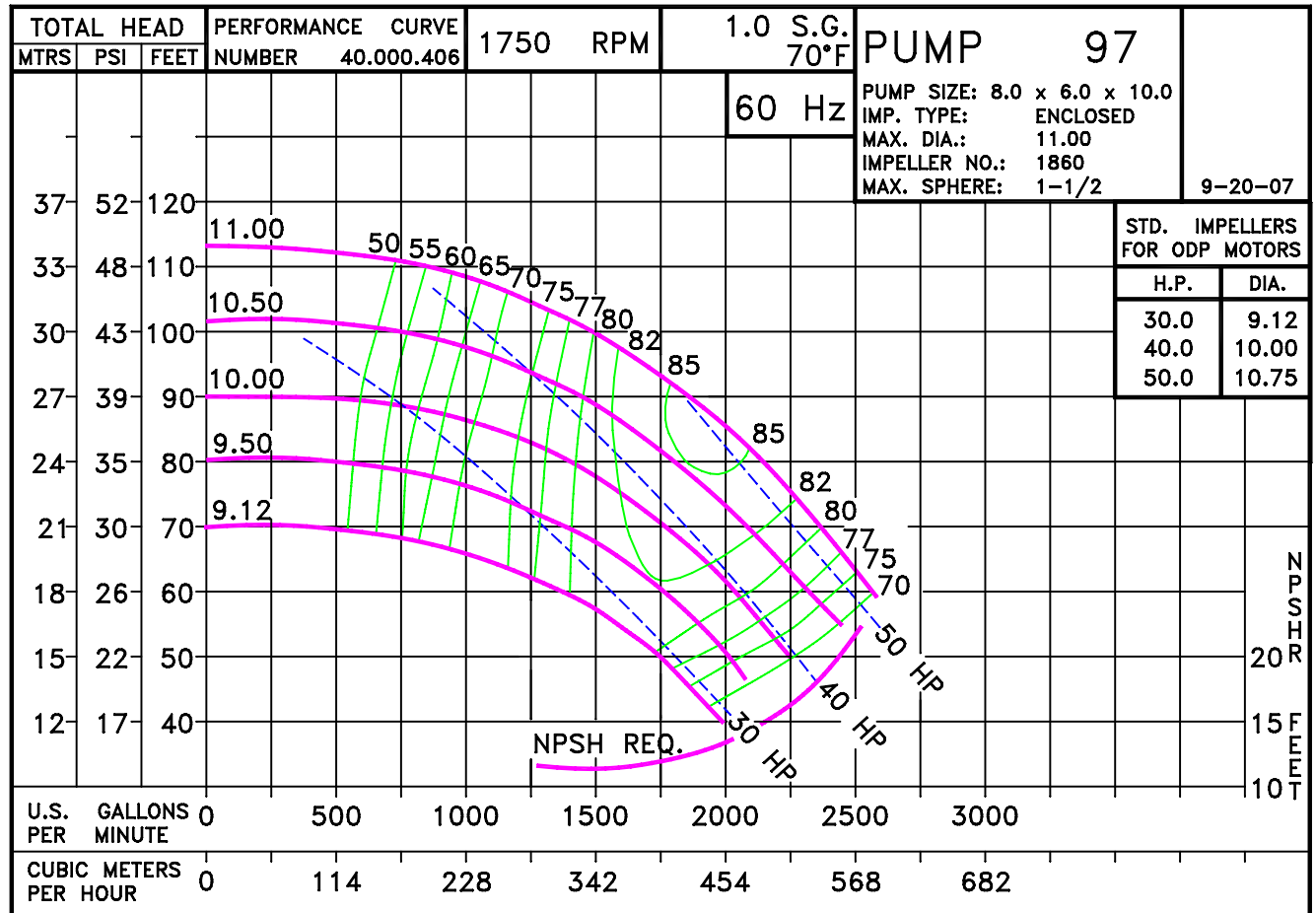

09740TE

D097JP324
0971750

Pump 97 • Iron • JP Frame • 1750 RPM

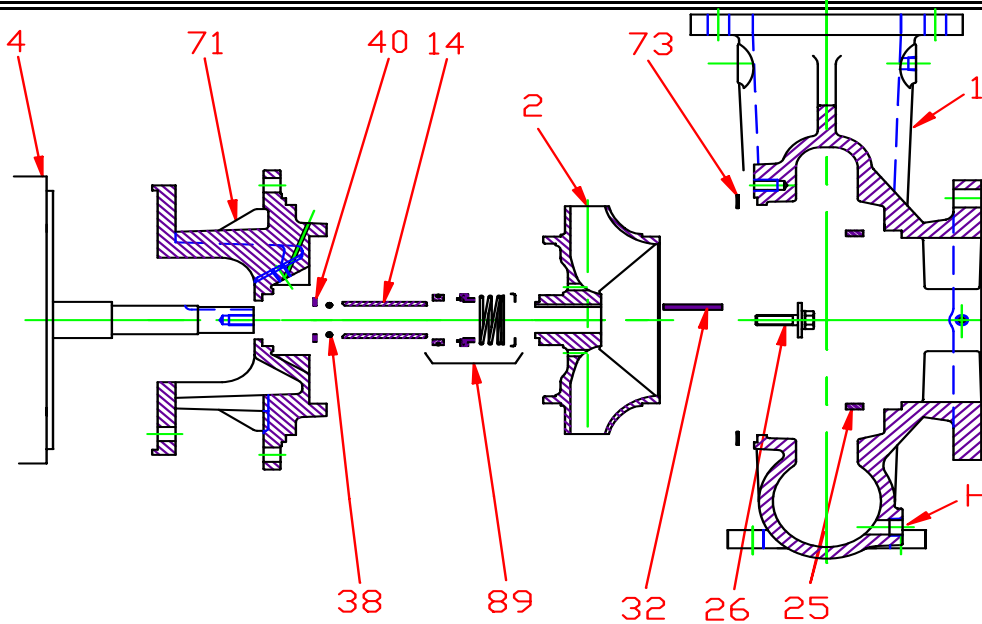

KEY NO.	PART NAME	PUMP NO. 97
1+	CASE, IRON, 8 x 6 FLG	130.000.325X
2	IMPELLER, 1¼" KEYED, ENCLOSED, SPECIFY DIAMETER: IRON	137.000.163
4	MOTOR, JP280/320	See Chart
14*	SHAFT SLEEVE, BRONZE SHAFT SLEEVE, STAINLESS	110.000.398 110.000.360
25	WEAR RING, CASE, BRONZE WEAR RING, CASE, STEEL	137.001.434 137.001.448
26*	IMPELLER RETAINER, STAINLESS	118.000.641
32*	KEY, STAINLESS	102.000.282
38*	O-RING, SHAFT, BUNA O-RING, SHAFT, VITON	116.000.218 116.000.218A
40*	FLINGER, STAINLESS	104.000.200
71	ADAPTER, IRON, JP280/320	137.001.365
73*	GASKET, CASE, FIBER	116.000.293
89*	1¾" SEALS: BN-CARB/CM VN-CARB/CM VN-CARB/SIL VN-SIL/SIL EPDM-CARB/SIL EPDM-SIL/SIL	101.000.196 101.000.216 101.000.221 101.000.231 101.000.196B 137.001.555
--	° REPAIR KITS: BN-CARB/CM SEAL VN-CARB/CM SEAL (S) VN-CARB/SIL SEAL VN-SIL/SIL SEAL (S) EPDM-CARB/SIL SEAL EPDM-SIL/SIL SEAL	118.000.406 118.000.406A 118.000.406B 118.000.406C 118.000.406D 118.000.406E

* DENOTES COMPONENTS INCLUDED IN REPAIR KIT.
 + INCLUDES BRONZE WEAR RING. FOR STEEL WEAR RING, REPLACE THE SUFFIX "X" WITH "X1"
 ° THE REPAIR KIT INCLUDES THE BRONZE SHAFT SLEEVE EXCEPT THE (S) INDICATED, WHICH IS STAINLESS WITH VITON SHAFT O-RING.

NOTE: DRAWING REPRESENTS CURRENT 1-PIECE ADAPTER.

Pump 97 • Iron • JP Frame • 1750 RPM

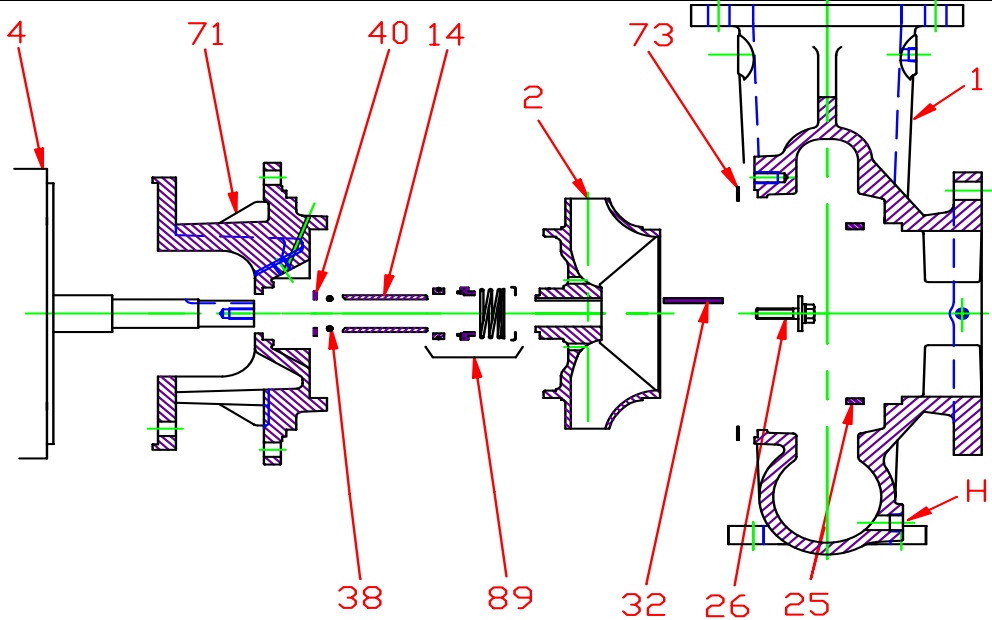

CONSTRUCTION OPTIONS			
KEY	PART NAME	STANDARD FITTED	ALL IRON
1	Case	Iron	Iron
2	Impeller	Iron	Iron
14	Shaft Sleeve	Bronze	Stainless
25	Wear Ring, Case	Bronze	Steel
26	Impeller Retainer	Stainless	Stainless
32	Key	Stainless	Stainless
38	Shaft O-Ring	BUNA	BUNA
40	Flinger	Stainless	Stainless
71	Adapter	Iron	Iron
73	Gasket, Case	Fiber	Fiber
89	Mechanical Seal, Type 21 BN-CM	Standard	Standard
H	Plug, Drain	Brass	Plated Steel

E097JP

M11

C0971750JP